

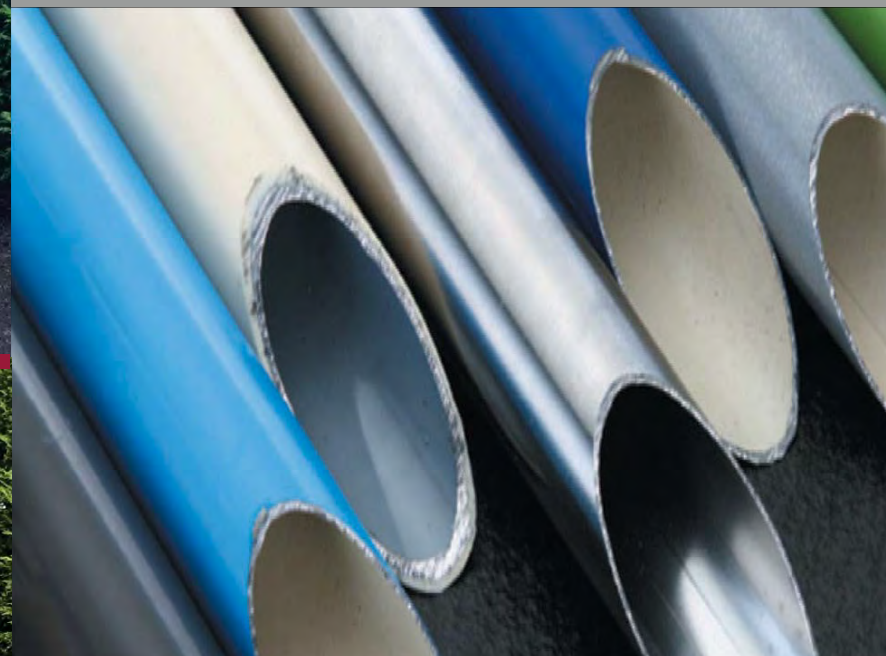

PIPES



pipes

- DP = Double Coated Pipe
- EP = COATED esd Pipe
- CS = Normal Coated Flat Pipe
- ES = Coated ESD slide Pipe
- CF = NORMAL COATED Flat Pipe
- EF = Coated ESD Stripe pipe
- CL = Coated Black stripe Pipe
- FS = Full Slide Pipe
- LS = L - Slide Pipe
- SP = Spiral Pipe
- S = STS Pipe















DP28 **07** **X**
 exemple : case of coated pipe Ivory Ø28 x t1.0 is DP2810-i

Thickness



















- 07 = t 0.7
- 09 = t 0.9
- 10 = t 1.0
- 20 = t 2.0

- Color Code**
- I = Ivory
 - N = Green
 - U = Blue
 - S = Sky Blue
 - K = Dark Blue
 - G = Gray
 - M = Metallic gray
 - Y = Dark gray
 - B = Black
 - L = Black tripe ESD Ivory
 - W = white
 - R = Red
 - O = Orange
 - A = Brown
 - RG = Rock Gray
 - YE = Yellow
 - P = Pink

COLOR TABLE

CLASSIFICATION STANDARD COLOR		Standard Length : 4000			
		Coated Pipe			
		Ø 28 X T1.0	Ø 28 X T2.0		
Normal Pipe	Ivory		✓	✓	
	Green		✓	✓	
	Blue		✓	✓	
	Sky Blue		✓	✓	
	Dark Blue		✓	✓	
	Gray		✓	✓	
	Rock Gray		✓	✓	
	Dark Gray		✓	✓	
	Black		✓	✓	
	White		✓	✓	
	Red		✓	✓	
	ESD Pipe 10 ³ Ω~10 ⁶ Ω	Orange		✓	✓
		Yellow		✓	✓
Pink			✓	✓	

NUMBERING SYSTEM

Classification	Item	Part No		Thickness	Weight (g) / M	Type	
		Normal	ESD				
Coated Pipe	D-Coated Pipe	DP2810-X	EP2810-X	Ø28 x T1.0	700		
		DP2820-X	EP2820-X	Ø28 x T2.0	1.130		
		DP3210-X	-	Ø32 x T1.0	810		
	Slide Pipe	CS2810-X	ES2810-X	Ø28 x T1.0	757		
	Full Slide Pipe	FS2807-X	FS2807-E	Ø28 x T0.7	505		
		FS2809-X	FS2809-E	Ø28 x T0.9	630		
	L. Slide Pipe	LS2810-X	LS2810-E	Ø28 x T1.0	500		
	Flat Pipe	CF2807-X	EF2807-X	Ø28 x T0.7	505		
		CF2810-X	EF2810-X	Ø28 x T1.0	690		
	Black Stripe Pipe	—	CL2807-X	Ø28 x T0.7	505		
		—	CL2810-X	Ø28 x T1.0	690		
	Tube W	RC2809 (Roller Conveyor)		Ø28 x T0.9	630		
	Spiral Pipe	SP2809		Ø28 x T0.9	630		
STS Pipe	Inox	S2807-PF		Ø28 x T0.7	448		
		S2812 - PF S2812-201 (inox non magnétique)		Ø28 x T1.2	760		

PIPE BENDING STRENGTH

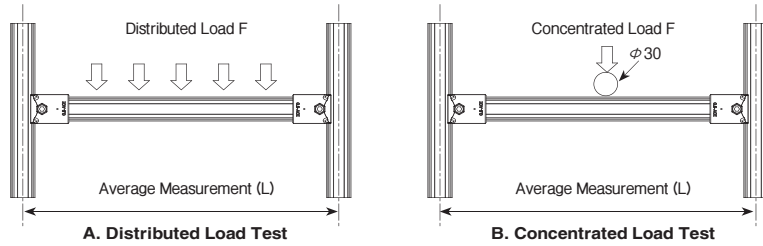

MODEL	TYPE	A. Distributed Load (kgf)			B. Concentrated Load (kgf)		
		L=270mm	L=900mm	L=1500mm	L=270mm	L=900mm	L=1500mm
AP2812SP		370	120	50	280	90	40
AP2820SP	X	370	120	50	280	90	40
	Y	500	150	70	380	110	45
AP2829SP		520	160	80	400	120	50
AR2812SP		300	130	60	240	90	40
AR2829SP		470	170	70	380	130	50
AT2829SP		570	140	100	400	100	60
AFS2812SA		280	130	60	190	90	40
ATF2812SP		380	140	60	290	100	50
ALF2812SP		360	140	60	270	100	50
AD2812SP	X	520	400	220	380	260	100
	Y	870	250	130	620	160	60
AD2829SP	X	680	550	310	500	360	150
	Y	1100	410	220	810	230	100

THE ADVANTAGES OF STAINLESS PIPE

- 1. Environmental**
- Stainless pipe which is 100% recyclable
- 2. High Strength & Durability**
- Surface resistant to light abrasion or contact with metal tools
- 3. High Oil & Chemical Resistance**
- High resistance to oil, solvents, bleaches, etc.
- 4. Non-Flammable**
- Inherently non-flammable.
- 5. Conductive**
- Inherently conductive

STS PIPE VS. COATED PIPE BENDING STRENGTH

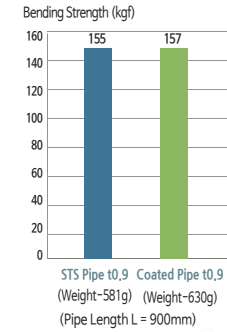

Stainless Pipe

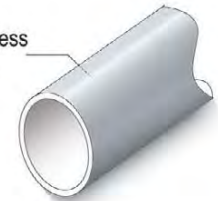

ALUMINIUM PIPES Ø 43

AP4319SP Regular Duty Pipe

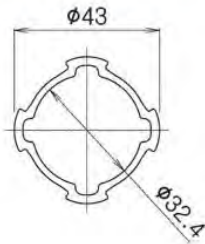

• Weight: 0.735kg/m, External Diameter Ø43

ALUMINIUM PIPES Ø 28

AP2812SP Regular Duty Pipe



• Weight: 0.378kg/m, External Diameter Ø28
 ※ Please refer to the technical data on the page 85

AP2829SP Heavy Duty Pipe



• Weight: 0.479kg/m, External Diameter Ø28
 ※ Please refer to the technical data on the page 85

AP2820SP Light Heavy Duty Pipe



• Weight: 0.440kg/m, External Diameter Ø28
 ※ Please refer to the technical data on the page 85



AR2812SP Round Pipe(Regular Duty)

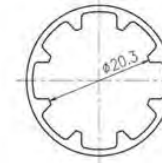

• Weight: 0.377kg/m, External Diameter Ø28
 ※ Please refer to the technical data on the page 85

AR2829SP Round Pipe(Heavy Duty)

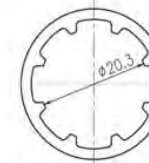

• Weight: 0.495kg/m, External Diameter Ø28
 ※ Please refer to the technical data on the page 85



AD2812SP Double Pipe (Heavy Duty)

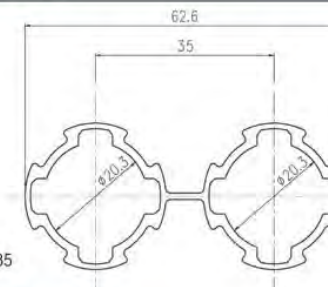

• Weight: 0.784kg/m, External Diameter Ø28
 ※ Please refer to the technical data on the page 85

AD2829SP Double Pipe (Extra Heavy Duty)

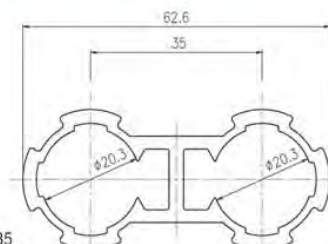

• Weight: 1.146kg/m, External Diameter Ø28
 ※ Please refer to the technical data on the page 85

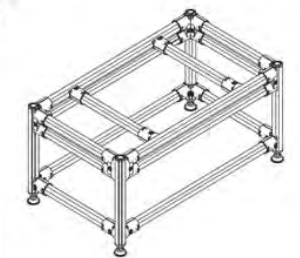

AT2829SP T Slot Pipe

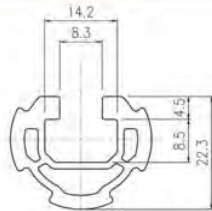

- Weight: 0.605kg/m, External Diameter Ø28
- ※ Spring Nuts (shown in Page 85) can be used in the slot to attach various items.
- ※ Slot will facilitate the linear movement of attached item

ATF2812SP T-Flat Pipe

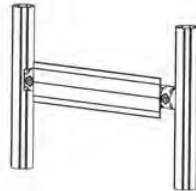
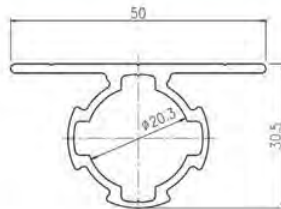

- Weight : 0.681kg/m, External Diameter Ø28
- ※ Please refer to the technical data on the page 85

ALF2812SP L-Flat Pipe

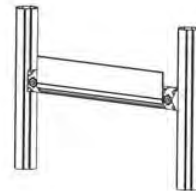
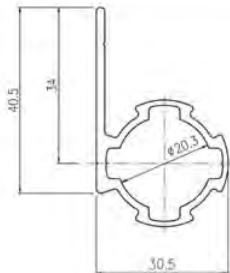

- Weight : 0.638kg/m, External Diameter Ø28
- ※ Please refer to the technical data on the page 85

AFS2812SA Full Slide Pipe

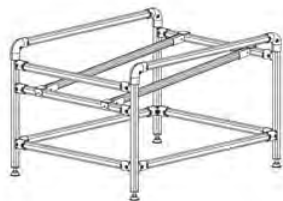

- Weight : 0.377kg/m, External Diameter Ø28
- ※ Sliding Pipe will facilitate the linear movement.

METAL JOINTS



COLORS

- Black
- White
- Nickel

S-Series Joint

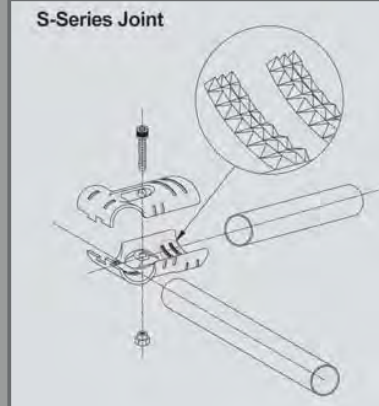

METAL JOINTS - SERIES FEATURES

- ✦ Developed and patented design for 28 stainless steel pipes.
- ✦ Excellent grip characteristics achieved by introducing series of protruded pyramids in contact with stainless steel pipes.
- ✦ When used with coated pipes, grip is enhanced by 30 %

SURFACE TREATMENT & CODE NUMBER

Code	Surface treatment	Remarks
BK	Black Coating	Non Chrome
WZ	Zinc Plating (white)	Cro3
Ni	Nickel Plating	Non Chrome

Unit : mm